



3825 Ohio Avenue, St. Charles, Illinois 60174
 1-800-SENSOR2, FAX: 630-377-6495
 www.systemsensor.com

FTX-P1 Filtrex® Intelligent Photoelectronic Smoke Detector

Specifications

Operating Voltage Range:	15 to 32 VDC
Detector Current:	250 µA @ 24 VDC (without communication) 360 µA @ 24 VDC (one communication every 99 communications with LED enabled)
Auxiliary Power Supply Voltage:	15 to 30 VDC filtered; Ripple voltage may not drop below 15 volts.
Auxiliary Power Supply Current:	
Peak:	123 mA max.
Average:	27 mA max.
Operating Humidity Range:	10% to 93% Relative Humidity, noncondensing
Operating Temperature Range:	0°C to 50°C (32°F to 122°F)
Height:	2.8 inches (43 mm)
Diameter:	6.1 inches (155 mm) installed in B501B-FTX 4.0 inches (102 mm) installed in B524FTXE
Weight:	7.3 oz. (207 g)
Compatibility:	Backwards compatible with 200 and 500 series products' protocol
Mounting Base:	Requires B501B-FTX (U.S.), B524FTXE (Europe)

Before Installing

This detector must be installed in compliance with the control panel system installation manual. The installation must meet the requirements of the Authority Having Jurisdiction (AHJ). Detectors offer maximum performance when installed in compliance with the National Fire Protection Association (NFPA); see NFPA 72.

General Description

Filtrex® uses a small air intake fan and a high density replaceable filter. Air and smoke are drawn into a photoelectric sensing chamber while airborne particulate and water mist are removed. The addressable-analog detector transmits an analog representation of smoke density over a communication line to a control panel. Rotary-decade switches are provided for setting the sensor's address. Two LEDs on the sensor are controlled by the panel to indicate sensor status.

Filtrex smoke detector is intended for use in normal environmental conditions, where dust and other airborne particulate are present at elevated levels. These elevated levels tend to cause false alarms and high maintenance in standard detectors. Filtrex provides a protective enclosure for a photoelectric smoke detector chamber and allows smoke detection in areas that tended to use exclusively heat detection.

Filtrex requires compatible addressable communications to function properly. Connect this detector to listed-compatible control panels only.

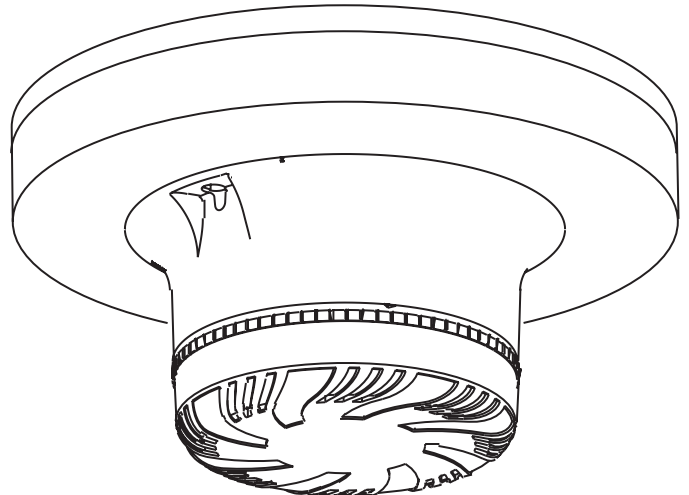

C0193-00

Spacing

System Sensor recommends spacing detectors in compliance with NFPA 72. In low air flow applications with smooth ceilings, space detectors 30 feet apart. For specific information regarding sensor spacing, placement, and special applications, refer to NFPA 72 or the System Sensor *Guide For Proper Use of System Smoke Detectors*, available from System Sensor (P/N 156-407-XX).



Filtrex is not designed to operate in explosive environments.

Figure 1. Wiring diagram:

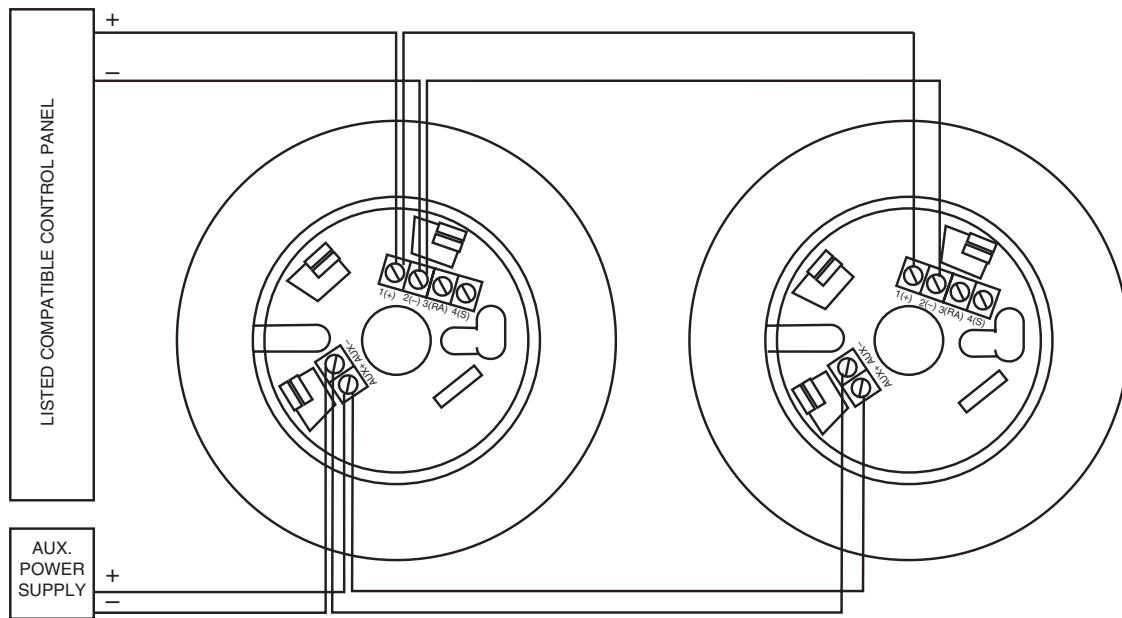

C0121-00

Wiring Instructions

All wiring must be installed in compliance with the National Electrical Code, applicable local codes, and any special requirements of the Authority Having Jurisdiction. Proper wire gauges should be used. The installation wires should be color-coded to limit wiring mistakes and ease system troubleshooting. Improper connections will prevent a system from responding properly in the event of a fire.

Remove power from the communication line before installing detectors.

All wiring must conform to applicable local codes, ordinances, and regulations.

1. Wire the sensor base per the wiring diagram, please see Figure 1.
2. Set the desired address on the sensor address switches, please see Figure 2.
3. Insert 5-wire connector on mounting base into 5-pin connector on Filtrex unit. Install the detector into the sensor base. Push the detector into the base while turning it clockwise to secure it in place. (Please see Figure 5 and INSTALLING FILTREX INTO BASE on page 4 for specific directions.
4. After all detectors have been installed, turn on the auxiliary power supply, then apply power to the control unit and activate the communication line.
5. Test the detector(s) as described in the TESTING section of this manual.

CAUTION

Dust cover must be removed before the detector can sense smoke.

Testing

Before testing, notify the proper authorities that the system is undergoing maintenance, and will temporarily be out of service. Disable the system to prevent unwanted alarms.

All detectors must be tested after installation and periodically thereafter. Testing methods must satisfy the Authority Having Jurisdiction (AHJ). Detectors offer maximum performance when tested and maintained in compliance with NFPA 72.

The sensor can be tested in the following ways:

A. Functional: Magnet Test (P/N M02-04-01 or M02-09-00)

This detector can be functionally tested with a test magnet. The test magnet electronically simulates smoke in the sensing chamber, testing the detector electronics and connections to the control panel.

1. Hold the test magnet in the magnet test area as shown in Figure 3.
2. The detector should alarm the panel. Two LEDs on the detector are controlled by the panel to indicate sensor status. Coded signals, transmitted from the panel, can cause the LEDs to blink, latch on, or latch off. Refer to the control panel technical documentation for detector LED status operation and expected delay to alarm.

B. Smoke Entry: Aerosol Generator

Aerosol generators for smoke entry testing are available from a number of third party manufacturers (e.g., Gemini Scientific). Following the manufacturer's instructions, apply aerosol until the panel alarms.

Figure 2. Rotary decade address switches:

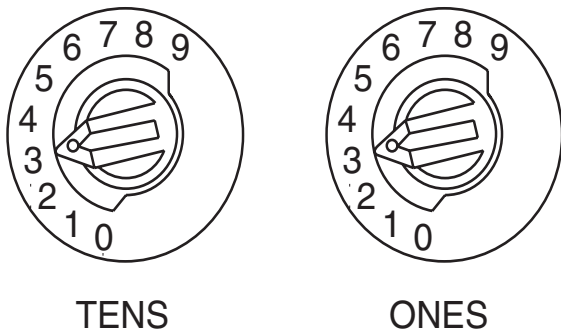

C0146-00

Figure 3. Test magnet position:

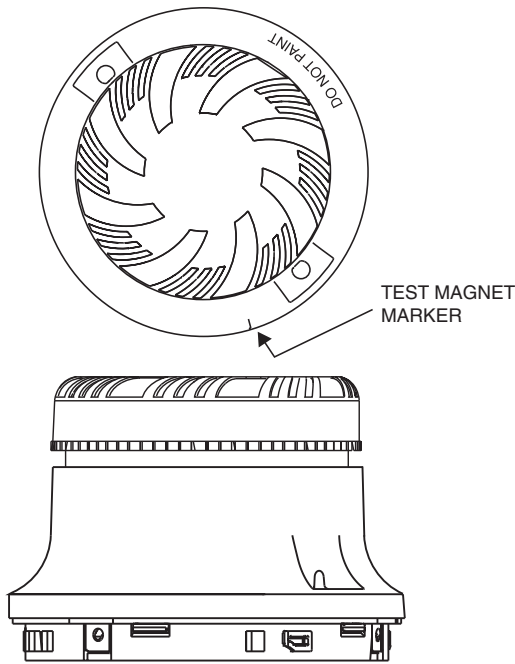

C0191-00

Figure 4. Replacing the filter cover:

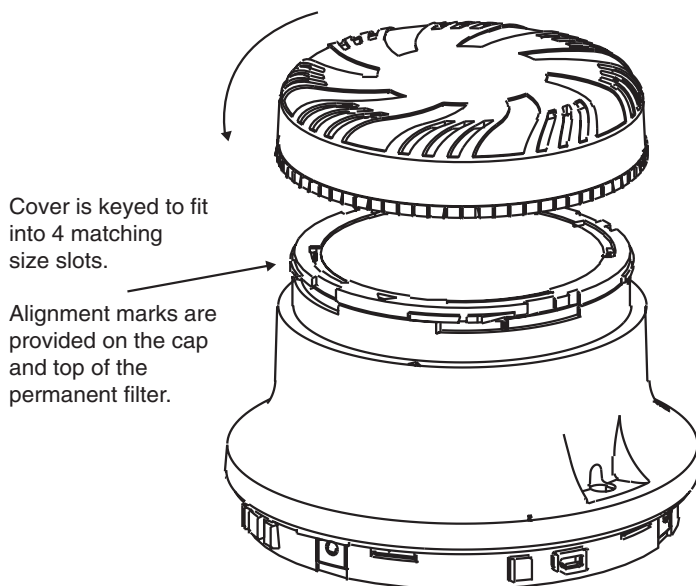

C0192-00

A detector that fails any of these tests should be retested. If the detector still fails any test, have its filter replaced (see instructions below) and retested. Finally, if the detector continues to fail after replacing the filter, it must be returned for repair or replacement.

When testing is complete, restore the system to normal operation and notify the proper authorities that the system is back in operation.

Cleaning

The unique design of Filtrex eliminates the need for typical detector cleaning. The only maintenance necessary is replacing the filter, which is signaled by a trouble condition at the panel (see below).

Filtrex has been designed to maximize the amount of time before maintenance is required. Filtrex utilizes a replaceable filter that may become clogged over time. Filtrex monitors itself to insure that the filter has not become clogged. Because environmental conditions can vary significantly, the amount of time before maintenance could vary significantly as well. To fully understand the maintenance requirements of Filtrex in its installed location, it is recommended that the following test program be conducted.

1. Install Filtrex in the desired location.
2. Connect Filtrex to the fire alarm control panel.
3. Maintain a record for at least 90 days of any maintenance performed on or required by Filtrex.
4. At the end of the test period, use the record to develop and schedule maintenance. Filtrex detectors should be serviced at regular intervals to insure that the fire alarm system provides continuous protection.

Replacing the Filter

IMPORTANT: When the filter becomes too clogged to draw adequate air into Filtrex, power is automatically cut from the detector, sending a trouble signal to the fire control panel. After 5 minutes, power is restored to the detector for 72 hours. After 72 hours, power is cut again and the detector will remain off-line until the filter is replaced.

NOTE: The unit has two filters. The replaceable filter is inside the cover. A permanent filter is mounted to the unit.

1. Grasp the Filtrex housing with one hand and the cover with the other. Turn the cover counterclockwise fully (approx. 30 degrees) and remove cover by pulling it away from detector unit (see Figure 4).
2. Replace with new filter and cover assembly. The cover is keyed so it fits in place only one way. Turn the cover clockwise until it stops.

NOTE: The base is equipped with an optional tamper proof feature which can be used to prevent unintentional removal of Filtrex while replacing the filter.

If a clogged filter was the cause of the trouble condition, normal detector operation should resume automatically within five minutes. If the trouble condition persists, the detector must be returned for repair or replacement.

Installing Filtrex Into Base

1. Align the detector at a right angle to the base, with the five wires and connector adjacent to the connector receptacle as shown in Figure 5.
2. Plug the wired connector into the receptacle.
3. Rotate the detector into the base, making sure detector and base keyed fit is lined up. Turn the detector clockwise until it snaps into place.

IMPORTANT: Filtrex will only operate with B501B-FTX/ B524FTXE Mounting Base.

Special Note Regarding Smoke Detector Guards

Smoke detectors are not to be used with detector guards unless the combination has been evaluated and found suitable for that purpose.

Figure 5: Installing Filtrex detector into base:



0845

 0845
SYSTEM SENSOR 3825 OHIO AVENUE, ST. CHARLES, IL, 60174 8021 U.S.A. 0845-CPD-232.1427
EN54-7: 2000 MODEL FTX-P1 Filtrex Point Optical Smoke Sensor for Harsh Areas

Please refer to insert for the Limitations of Fire Alarm Systems

Three-Year Limited Warranty

System Sensor warrants its enclosed air duct smoke detector to be free from defects in materials and workmanship under normal use and service for a period of three years from date of manufacture. System Sensor makes no other express warranty for this air duct smoke detector. No agent, representative, dealer, or employee of the Company has the authority to increase or alter the obligations or limitations of this Warranty. The Company's obligation of this Warranty shall be limited to the replacement of any part of the air duct smoke detector which is found to be defective in materials or workmanship under normal use and service during the three year period commencing with the date of manufacture. After phoning System Sensor's toll free number 800-SENSOR2 (736-7672) for a Return Authorization number, send defective units postage prepaid to:

System Sensor, Returns Department, RA # _____, 3825 Ohio Avenue, St. Charles, IL 60174. Please include a note describing the malfunction and suspected cause of failure. The Company shall not be obligated to replace units which are found to be defective because of damage, unreasonable use, modifications, or alterations occurring after the date of manufacture. In no case shall the Company be liable for any consequential or incidental damages for breach of this or any other Warranty, expressed or implied whatsoever, even if the loss or damage is caused by the Company's negligence or fault. Some states do not allow the exclusion or limitation of incidental or consequential damages, so the above limitation or exclusion may not apply to you. This Warranty gives you specific legal rights, and you may also have other rights which vary from state to state.

FCC Statement

This device complies with part 15 of the FCC Rules. Operation is subject to the following two conditions: (1) This device may not cause harmful interference, and (2) this device must accept any interference received, including interference that may cause undesired operation.

NOTE: This equipment has been tested and found to comply with the limits for a Class B digital device, pursuant to Part 15 of the FCC Rules. These limits are designed to provide reasonable protection against harmful interference in a residential installation. This equipment generates, uses and can radiate radio frequency energy and, if not installed and used in accordance with the instructions, may cause harmful interference to radio communications. However, there is no guarantee that interference will not occur in a particular installation. If this equipment does cause harmful interference to radio or television reception, which can be determined by turning the equipment off and on, the user is encouraged to try to correct the interference by one or more of the following measures:

- Reorient or relocate the receiving antenna.
- Increase the separation between the equipment and receiver.
- Connect the equipment into an outlet on a circuit different from that to which the receiver is connected.
- Consult the dealer or an experienced radio/TV technician for help.