



3825 Ohio Avenue, St. Charles, Illinois 60174
 1-800-SENSOR2, FAX: 630-377-6495
 www.systemsensor.com

B501BHT

Temporal Tone Sounder Base

Specifications

Base Diameter:	6.0 inches (15.2 cm)
Base Height (less sensor):	2.3 inches (5.9 cm)
Weight:	0.4 lb. (181 gm)
Operating Temperature Range:	32° to 120°F (0° to 49°C)
Operating Humidity Range:	10% to 93% Relative Humidity

Electrical Ratings

External Supply Voltage:	17 to 32 VDC
Standby Current:	1.0 mA maximum
Alarm Current:	15 mA maximum
Maximum Ripple Voltage:	10% of supply voltage
Start-up Capacitance:	200 µF

Communication/Initiating Loop Supply

Current Draw from Remote Output

of Sensor to turn on Horn:	700 µA maximum
Sound Output:	Greater than 90 dBA measured in anechoic room at 10 feet, 24 volts. 85 dBA minimum measured in UL reverberant room.

Before Installing

Please read the System Smoke Detector Application Guide, which provides detailed information on sensor spacing, placement, zoning, wiring, and special applications. Copies of this manual are available from System Sensor. NFPA 72 and NEMA guidelines should be observed.

NOTICE: This manual should be left with the owner/user of this equipment.

IMPORTANT: The detector used with this base must be tested and maintained regularly following NFPA 72 requirements. The detector should be cleaned at least once a year.

General Description

The B501BHT sounder base is used with System Sensor 200 and 500 Series sensor heads. Refer to the appropriate manual for more information on sensors.

The B501BHT incorporates the distinctive three-pulse temporal pattern fire alarm evacuation signal now required by NFPA 72 for commercial and residential applications.

The sounder base is intended for use with intelligent systems. Refer to the panel manual for the maximum allowable number of units per loop. The sounder base requires an external 24VDC supply with reverse polarity capability or a relay module configured to reverse the power as in **Figure 5**. The connections for the external supply (terminals 1 and 2) and the communication loop (terminals 3 and 4) are isolated to prevent electrical interaction between them.

When the sensor's visible LEDs are latched on for approximately 10 seconds, the associated horn sounds. A loop of horns can be made to sound by reversing the polarity of the external supply when configured as in **Figure 4** and **5**. When configured as in **Figure 5**, a loop of horns can also be made to sound by turning on the Intelligent Relay Module.

NOTE: When not used as a supplementary evacuation system the external 24 VDC supply shall be treated as a component of the main power supply system and shall fall under the requirements of the main power supply system per NFPA 72.

B501BHT Terminals

No.	Function
1	External Supply Positive (+)
2	External Supply Negative (-)
3	Negative (-) Comm. Line In and Out
4	Positive (+) Comm. Line In and Out
5	Sounder Base Interconnect

Terminals 3 and 4 are used for the communication circuit.

Mounting

Mount the B501BHT directly to an electrical box, using the mounting kit, supplied (see **Figure 2**).

The sounder base is 1.1-inches deep. Electrical boxes must be 4-inches square by at least 1½ inches deep - 2⅛ inches is recommended.

NOTE: A maximum space of ⅛ inch from the outside edge of the electrical box to the inside edge of the drywall or ceiling tile is allowable.

Wiring Guidelines

All wiring must be installed in compliance with the National Electrical Code and the local codes having jurisdiction and must not be of such length or wire size which would cause the base to operate outside of its published specifications. The conductors used to connect smoke sensors to control panels and accessory devices should be color coded to reduce the likelihood of wiring errors. Improper connections can prevent a system from responding properly in the event of a fire.

For signal wiring (the wiring between interconnected sensors or modules), it is recommended that the wire be no smaller than 18 gauge (1.0 square mm). Wire sizes up to 12 gauge (2.5 square mm) may be used with the base. For best system performance, the power (+ and -) wires and the communication circuit wires should be twisted pair or shielded cable installed in separate grounded conduit to protect the communication loop from electrical interference.

Make wire connections by stripping about $\frac{3}{8}$ " of insulation from the end of the wire. Then, slide the bare end of the wire under the clamping plate, and tighten the clamping plate screw. Do NOT loop the wire under the clamping plate (See **Figure 3**).

The zone wiring of the sensor base should be checked before the sensor heads are installed. Check the wiring for continuity and polarity in the base.

See the individual sensor manual for the maximum sensor installation temperature.

Wiring Instructions

NOTE: External supply shown in normal standby configuration in **Figure 4** and **5**.

The wiring diagram for a typical 2-wire intelligent system is shown in **Figure 4** and **5** (the monitor module is supervising the external supply).

Testing

Sensors and bases must be tested after installation and as an integral part of periodic maintenance. Test the B501BHT as follows:

NOTE: Before testing, notify the proper authorities that the smoke sensor system is undergoing maintenance and, therefore, will be temporarily out of service. Disable the system undergoing maintenance to prevent unwanted alarms.

1. If configured as in **Figure 4** or **5**, reverse the polarity of the external 24VDC supply. If configured as in **Figure 5**, turn on the Intelligent Relay Module. All B501BHT bases on the loop should sound in approximately 10 seconds.
2. Latch the sensor LED on from the control panel. That unit's B501BHT should sound in approximately 10 seconds.

NOTES:

1. There is approximately a 10 second delay built into the B501BHT before sounding. This delay is present whether the control signal comes from the sensor or from the external power supply polarity being reversed.
2. During automatic testing cycles, the horn may sound if the associated sensor is left in the test mode with LEDs latched on for more than 4 seconds. Therefore, it is necessary to complete testing of each sensor within this 4-second limit to prevent the horn from sounding.

Figure 1. Terminal layout:

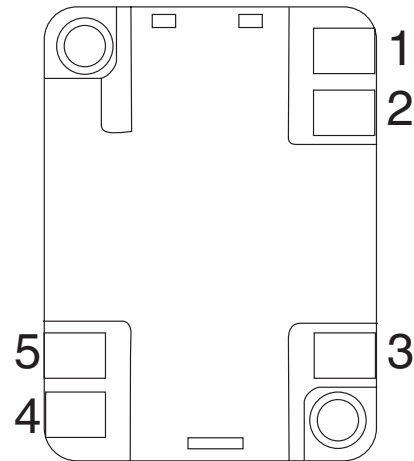

C0736-00

Figure 2. Mounting:

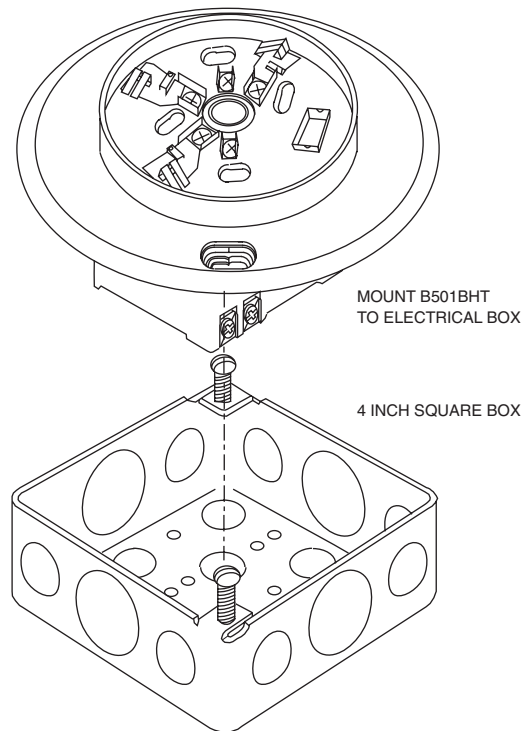

C0472-00

Figure 3:

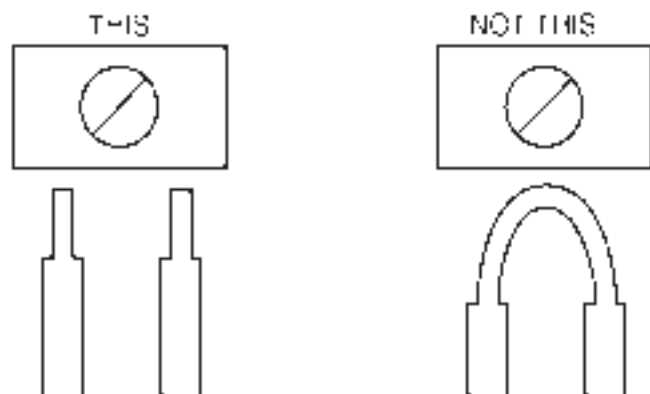

C0473-00

**Figure 4. Wiring diagram:
Detector Activates Sounder Base(s) - (Complies with UL268)**

UL has approved grouping for up to six B501BHT base with horn units. When wired as a group, any detector in the group that has its LED's latched on by the panel will cause other B501BHT units in the group to sound. This type of "local" grouping is accomplished by wiring the grouped devices to-

gether using terminal 5, Sounder Base Interconnect, as shown in the diagram.

NOTE: Since a local grouping of horns is not supervised, the groups can only be used as a supplementary evacuation system. It is not acceptable to group horns for primary alarm signaling.

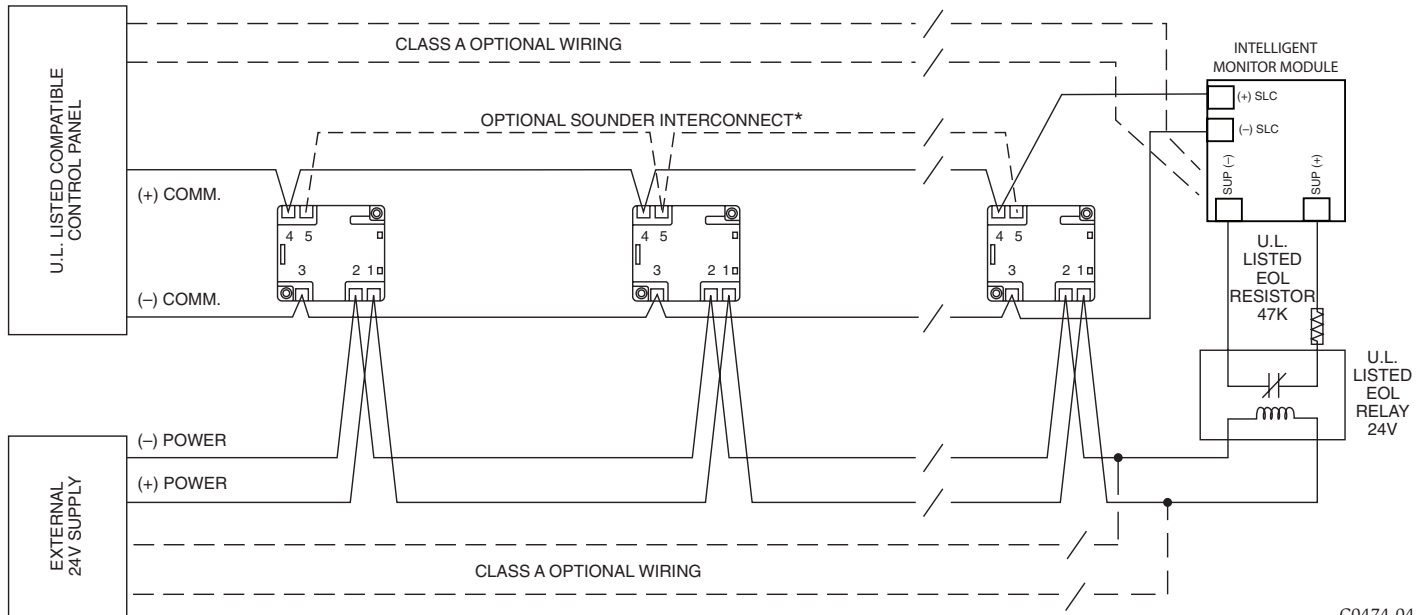

C0474-04

*GROUPING OF UP TO 6 MODEL B501BHT TEMPORAL TONE SOUNDER BASES.

**Figure 5. Wiring diagram:
Detector Activates Sounder Base(s); Intelligent Relay Module Activates All Sounder Bases - (Complies with UL 268 and UL 464)**

UL has approved grouping of up to six B501BHT bases with horn units. When wired as a group, any detector in the group that has its LED's latched on by the panel will cause other B501BHT units in the group to sound. This type of "local" grouping is accomplished by wiring the grouped devices to-

gether using terminal 5, Sounder Base Interconnect, as shown in the diagram.

NOTE: Since a local grouping of horns is not supervised, the groups can only be used as a supplementary evacuation system. It is not acceptable to group horns for primary alarm signaling.

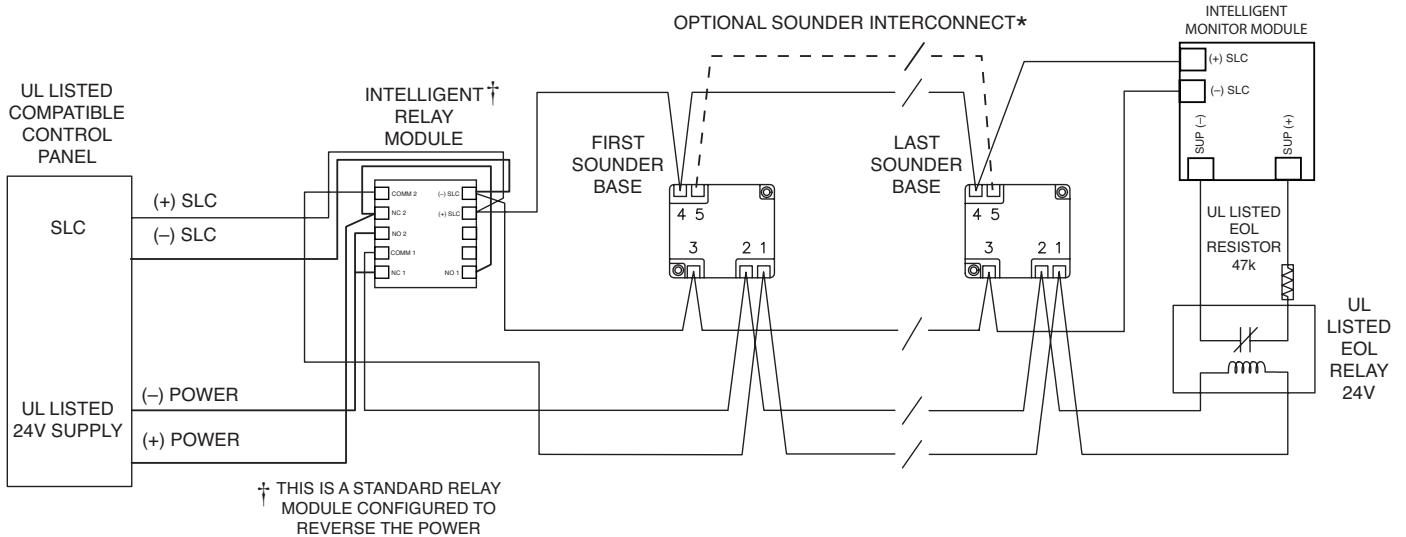

† THIS IS A STANDARD RELAY MODULE CONFIGURED TO REVERSE THE POWER

C0968-01

*GROUPING OF UP TO 6 MODEL B501BHT TEMPORAL TONE SOUNDER BASES.

Please refer to insert for the Limitations of Fire Alarm Systems

THREE-YEAR LIMITED WARRANTY

System Sensor warrants its enclosed smoke detector base to be free from defects in materials and workmanship under normal use and service for a period of three years from date of manufacture. System Sensor makes no other express warranty for this smoke detector base. No agent, representative, dealer, or employee of the Company has the authority to increase or alter the obligations or limitations of this Warranty. The Company's obligation of this Warranty shall be limited to the repair or replacement of any part of the smoke detector base which is found to be defective in materials or workmanship under normal use and service during the three year period commencing with the date of manufacture. After phoning System Sensor's toll free number 800-SENSOR2 (736-7672) for a Return Authorization number, send defective units postage prepaid to: System Sensor, Returns

Department, RA # _____, 3825 Ohio Avenue, St. Charles, IL 60174. Please include a note describing the malfunction and suspected cause of failure. The Company shall not be obligated to repair or replace units which are found to be defective because of damage, unreasonable use, modifications, or alterations occurring after the date of manufacture. In no case shall the Company be liable for any consequential or incidental damages for breach of this or any other Warranty, expressed or implied whatsoever, even if the loss or damage is caused by the Company's negligence or fault. Some states do not allow the exclusion or limitation of incidental or consequential damages, so the above limitation or exclusion may not apply to you. This Warranty gives you specific legal rights, and you may also have other rights which vary from state to state.