



3825 Ohio Avenue, St. Charles, Illinois 60174
 800/736-7672, FAX: 630/377-6495
 www.systemsensor.com

CZ-6 Six Zone Interface Module

SPECIFICATIONS

Normal Operating Voltage:	15-32 VDC
Stand-By Current:	2 mA
Alarm Current:	40 mA (assumes all six LEDs solid on)
Temperature Range:	32°F to 120°F (0°C to 49°C)
Humidity:	10 to 93% Non-condensing
Dimensions:	6.8"H x 5.8"W x 1.25"D
Accessories:	CH-6 Chassis; BB-2 Cabinet; BB-6 Cabinet
Wire Gauge:	12-18 AWG
Maximum IDC Wiring Resistance:	25 Ohms
External Power Supply Voltage:	Regulated 24VDC
Ripple Voltage:	0.1 volts RMS maximum
IDC (supervised and power limited)	
DC Voltage:	18-28 volts power limited
Frequency:	DC
Current:	90mA per circuit

BEFORE INSTALLING

This information is included as a quick reference installation guide. Refer to the appropriate control panel installation manual for detailed system information. If the modules will be installed in an existing operational system, inform the operator and local authority that the system will be temporarily out of service. Disconnect the power to the control panel before installing the modules. This system contains static sensitive components. Always ground yourself with a proper wrist strap before handling any circuits so that static charges are removed from the body. The module housing should also be grounded.

NOTICE: This manual should be left with the owner/user of this equipment.

GENERAL DESCRIPTION

The CZ-6 Six Zone Interface Module is intended for use in an intelligent alarm system. Each module provides an interface between the intelligent alarm system and a conventional alarm system loop. A common SLC input is used for all modules, and the initiating device loops share a common supervisory supply and ground. Otherwise, each monitor operates independently from the others. Each module has its own unique address.

A pair of rotary code switches is used to set the address of the first module from 01 to 94. The remaining modules are automatically assigned to the next five higher addresses. Provisions are included for disabling a maximum of two unused modules to release the addresses to be used elsewhere. Each module also has panel controlled bicolor LED indicators. The panel can cause the LEDs to blink, latch on, or latch off.

Compatible Two-wire System Sensor Smoke Detectors for use with CZ-6 with Zone Identifier A

DET. MODEL	COMP. ID	DETECTOR MANUFACTURER	BASE MODEL	MAX DET.
1151	A	SYSTEM SENSOR	B110LP, B401	20
1451	A	SYSTEM SENSOR	B401, B401B	20
1451DH	A	SYSTEM SENSOR	DH400	20
2151	A	SYSTEM SENSOR	B110LP, B401	20
2451	A	SYSTEM SENSOR	DH400, B401B, B401	20
2451TH	A	SYSTEM SENSOR	B401, B401B	20
5451	A	SYSTEM SENSOR	B401	20
1100	A	SYSTEM SENSOR	N/A	20
1400	A	SYSTEM SENSOR	N/A	20
**2100AT	A	SYSTEM SENSOR	N/A	20
2100B	A	SYSTEM SENSOR	N/A	20
2100D	A	SYSTEM SENSOR	N/A	20
2100S	A	SYSTEM SENSOR	N/A	20
2100TB	A	SYSTEM SENSOR	N/A	20
2100TD	A	SYSTEM SENSOR	N/A	20
2100TS	A	SYSTEM SENSOR	N/A	20
2300B	A	SYSTEM SENSOR	N/A	20
2300TB	A	SYSTEM SENSOR	N/A	20
2400	A	SYSTEM SENSOR	N/A	20
2400TH	A	SYSTEM SENSOR	N/A	20
* 2W-B	A	SYSTEM SENSOR	N/A	20
* 2W-TB	A	SYSTEM SENSOR	N/A	20
DH100LP	A	SYSTEM SENSOR	N/A	20

* Class B, Style B only

** No Accessory will be supported by 2100AT

Included:

- (5) 1 x 4 Terminal Blocks
- (2) 1 1/4" Stand offs
- (3) Shunts

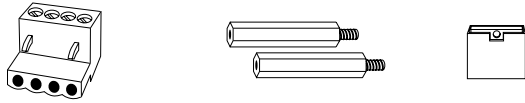

- (4) Machine Screws
- (2) Nuts
- (1) Long Power Supply Jumper

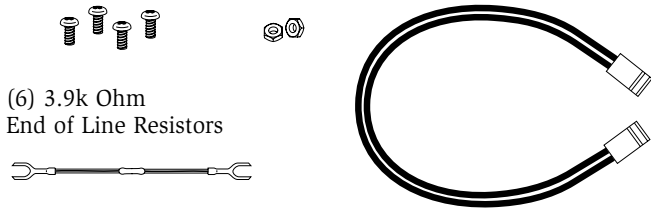

Shipped on Board:

- (2) Shunts in Class A/B position
(Shipped in Class B position, remove shunts for Class A)

C0202-00

COMPATIBILITY REQUIREMENTS

To ensure proper operation, this module shall be connected to a compatible system control panel. Contact System Sensor for a list of compatible detectors.

COMPONENTS

Following are descriptions of the CZ-6 mounting frameworks. There are two mounting options for CZ-6 modules:

- Up to six CZ-6 modules can be installed on a CH-6 in a BB-6 cabinet
- One or two CZ-6 modules can be installed in a BB-2 cabinet

Chassis

The CH-6 chassis is used to mount CZ-6 modules in a BB-6, cabinet. It accommodates up to six CZ-6 modules in a single cabinet row three modules wide and two modules deep.

Figure 1. CH-6 Chassis:

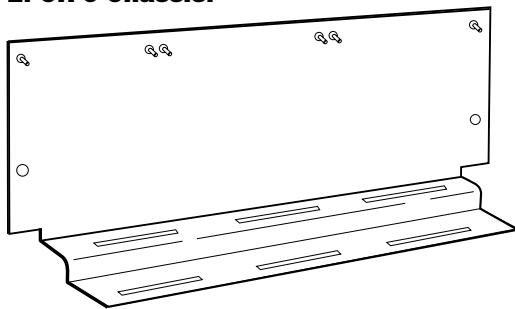

C0206-00

The BB-2 cabinet has a built-in chassis that will accommodate one or two CZ-6 modules.

Figure 2: BB-2 Cabinet

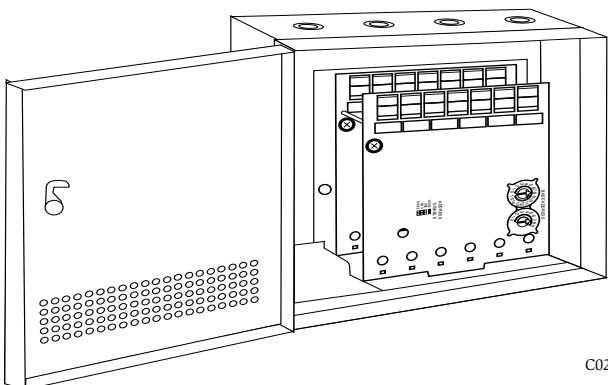

C0234-00

The front CZ-6 module positions of each chassis are offset below the rear CZ-6 module positions so that all of the status indicators are visible.

Cabinets

A BB-6 cabinet will house the CH-6 chassis with up to six CZ-6 modules installed on it. Refer to cabinet installation documents for dimensions.

The BB-2 cabinet houses one or two CZ-6 modules on the internal chassis that is part of the cabinet. Refer to cabinet installation documents for dimensions.

INSTALLATION STEPS

1. Cabinet Mounting

In a clean, dry area, mount the backbox using the four holes provided in the back surface of the cabinet (Figure 3).

2. Chassis Installation

The CH-6 chassis is mounted in the BB-6 cabinet. It is shipped with two self-threading screws, which are used to fasten the chassis to the back wall of the cabinet. (Figure 4).

Figure 3. Typical mounting hole locations:

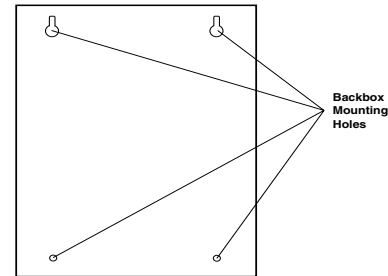

C0235-00

Figure 4. Mounting the CH-6 chassis:

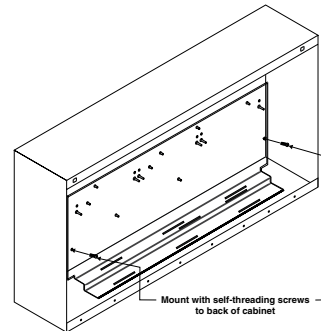

C0236-00

The BB-2 cabinet comes with the chassis already installed, so no mounting is necessary.

3. Module Installation

There are two methods for installing a module in the rear position of a chassis. Method one is for installation of a rear module only, when no module will be installed in front of it. Refer to Figure 5 for instructions. Method two is for installation of a rear module when another module will be installed in the chassis position in front of it. Refer to Figures 6a and 6b for method two. All necessary screws and standoffs are supplied with the modules.

Figure 5. Installation of rear module only, method one:

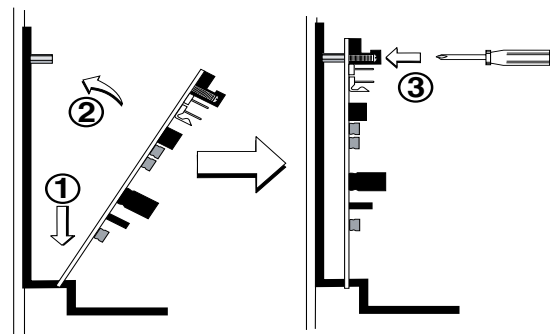

C0237-00

- Step 1: Insert the bottom of the CZ-6 module down into a rear slot on the chassis.
- Step 2: Carefully swing the upper edge of the board back towards the back of the chassis until it touches the two standoffs.
- Step 3: Align two 4-40 screws with the two standoffs and tighten.
- Step 4: Address and wire the modules according to the instructions in this manual.

The steps in Figures 6a and 6b describe and illustrate module installation when the rear chassis position and the position in front of it will be filled. Front position installation is possible only if the rear position is filled with another module.

Figure 6a. Installation of CZ-6 module in a rear chassis position, method two:

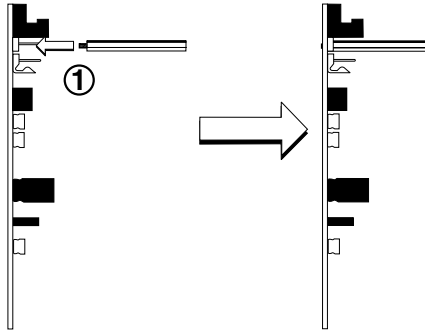

- Step 1: Insert the bottom edge of the CZ-6 module down into a rear slot of the chassis.
- Step 2: Carefully swing the upper edge of the board towards the back of the chassis until it touches the short standoff attached to the chassis.
- Step 3: Align the long standoff with the short standoff and tighten.

Figure 6b. Installation of CZ-6 module in front chassis position:

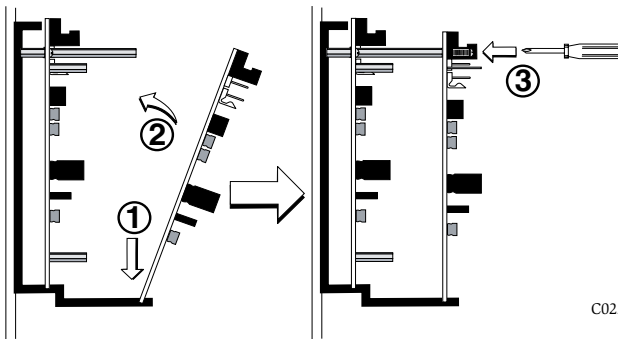

- Step 1: Insert the bottom edge of the CZ-6 module down into a front slot of the chassis.
- Step 2: Carefully swing the upper edge of the board towards the back of the chassis until it touches the 1¹/₄" (31.75mm) standoffs installed on the rear module.

- Step 3: Align two 4-40 screws with the two standoffs and tighten.
- Step 4: Address and wire the modules according to the instructions in this manual.

WIRING

NOTE: All wiring must conform to applicable local codes, ordinances, and regulations.

1. Install module wiring in accordance with the job drawings and appropriate wiring diagrams.
2. All wiring to the CZ-6 is done via terminal blocks. In order to properly make electrical connections strip approximately 1/4 of insulation from the end of wire, sliding the bare end of the wire under the clamping plate screw.
3. Set the address on the modules per the job drawing. Use the rotary code switches to set the address of the first module (between 01 and 94).

In Class B operation, the remaining modules are automatically assigned to the next five higher addresses. For example, if the base address switch is set to 28, the next five modules will be addressed to 29, 30, 31, 32 and 33.

The module is shipped in Class B position, remove shunts for Class A. When operating in Class A, alternate modules are paired together (+0/+1, +2/+3, +4/+5), resulting in a total of three modules. For example, if the base address switch is set to 28, then 30 and 32 will be automatically assigned to the modules while 29, 31 and 33 are available to be used for other modules on the SLC. For Class A and B operation, DO NOT set the lowest address above 94, as the other modules will be assigned to nonexistent addresses.

4. A shunt is provided to disable a maximum of two unused modules in Class B operation and Class A operation. Modules are disabled from the highest address and work downward. If two modules are disabled, the lowest four addresses will be functional, while the highest two will be disabled. For example, in Class B operation, if the shunt for Address Disable is placed on "two" and the base switch is set to 28, the modules will be assigned to 28, 29, 30 and 31 while disabling the highest two positions.

NOTE: Place unused shunts on single pin to store on board for future use.

NOTE: Power must not be applied to the unit when changing functionality of the shunts.

WIRING NOTES

- Power-limited circuits must employ type FPL, FPLR, or FPLP cable as required by Article 760 of the NEC.
- All wiring must be in accordance with the NEC, NFPA 72 and all other applicable codes and standards. All external power supplies must be power limited with battery back-up. All external power supplies and detectors must be UL listed for fire protection signaling applications.

FCC Statement

This device complies with part 15 of the FCC Rules. Operation is subject to the following two conditions: (1) This device may not cause harmful interference, and (2) this device must accept any interference received, including interference that may cause undesired operation.

NOTE: This equipment has been tested and found to comply with the limits for a Class B digital device, pursuant to Part 15 of the FCC Rules. These limits are designed to provide reasonable protection against harmful interference in a residential installation. This equipment generates, uses and can radiate radio frequency energy and, if not installed and used in accordance with the instructions, may cause harmful interference to radio communications. However, there is no guarantee that interference will not occur in a particular installation. If this equipment does cause harmful interference to radio or television reception, which can be determined by turning the equipment off and on, the user is encouraged to try to correct the interference by one or more of the following measures:

- Reorient or relocate the receiving antenna.
- Increase the separation between the equipment and receiver.
- Connect the equipment into an outlet on a circuit different from that to which the receiver is connected.
- Consult the dealer or an experienced radio/TV technician for help.

Figure 7. Interface two-wire conventional detectors – Class B, Style B:

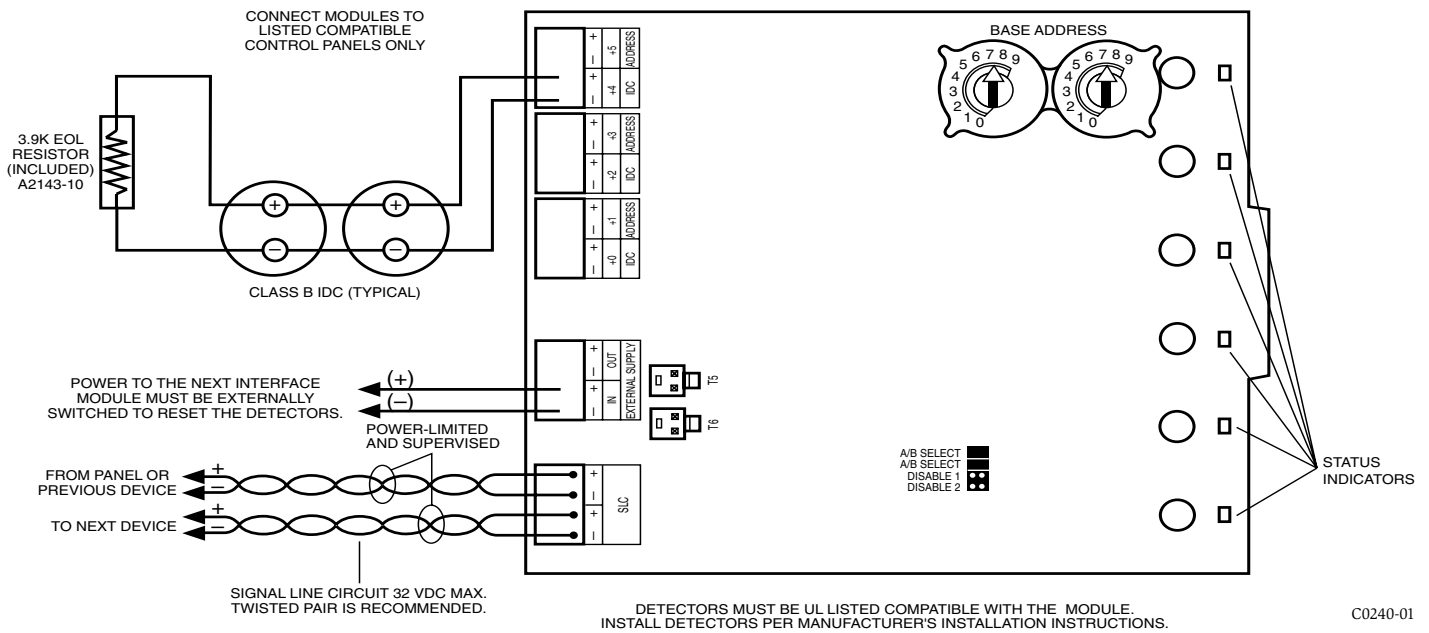

1. To use a common power supply between multiple CZ-6 modules, connect a long power supply jumper from T5 or T6 to T5 or T6 on the adjacent CZ-6 module.

Figure 8. Interface two-wire conventional detectors – Class A, Style D.:

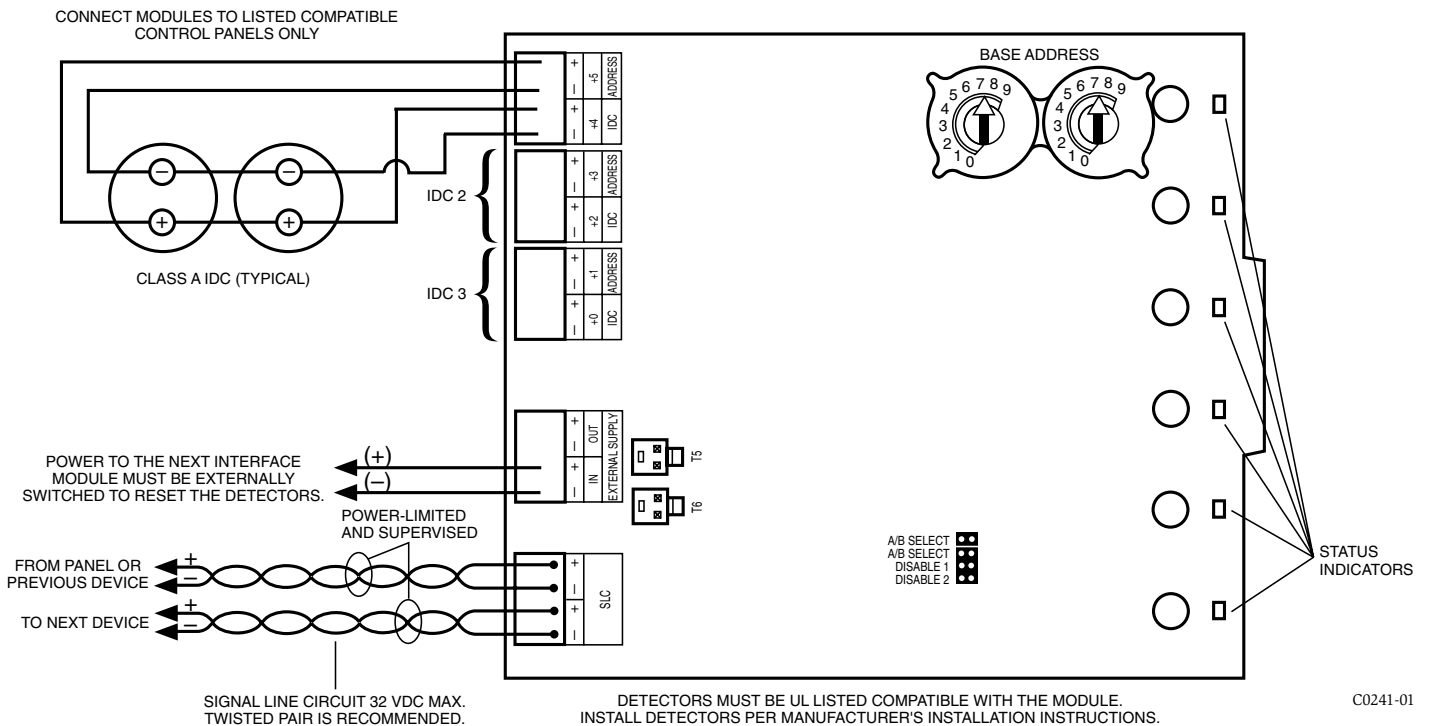

1. To select Class A, remove the two shunts from the "A/B select" positions.
2. To use a common power supply between multiple CZ-6 modules, connect a long power supply jumper from T5 or T6 to T5 or T6 on the adjacent CZ-6 module.

Figure 10. Example of multiple boards sharing same external supply. Refer to figures 7 and 8 for typical wiring. Make certain lip on long power supply jumper engages retaining tab on T5 or T6 as shown in View A-A:

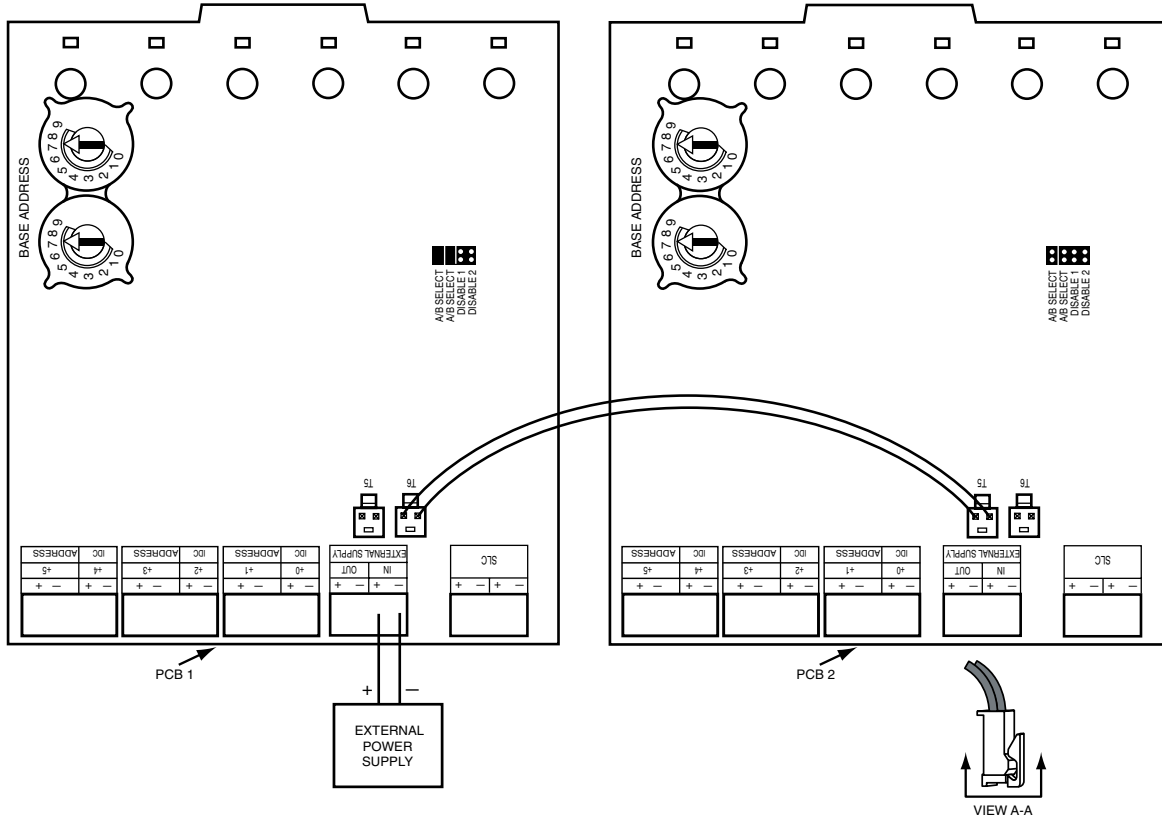

C0242-00

Three-Year Limited Warranty

System Sensor warrants its enclosed product to be free from defects in materials and workmanship under normal use and service for a period of three years from date of manufacture. System Sensor makes no other express warranty for the enclosed product. No agent, representative, dealer, or employee of the Company has the authority to increase or alter the obligations or limitations of this Warranty. The Company's obligation of this Warranty shall be limited to the replacement of any part of the product which is found to be defective in materials or workmanship under normal use and service during the three year period commencing with the date of manufacture. After phoning System Sensor's toll free number 800-SENSOR2 (736-7672) for a Return Authorization number, send defective units postage prepaid to: System Sensor, Returns

Department, RA # _____, 3825 Ohio Avenue, St. Charles, IL 60174. Please include a note describing the malfunction and suspected cause of failure. The Company shall not be obligated to replace units which are found to be defective because of damage, unreasonable use, modifications, or alterations occurring after the date of manufacture. In no case shall the Company be liable for any consequential or incidental damages for breach of this or any other Warranty, expressed or implied whatsoever, even if the loss or damage is caused by the Company's negligence or fault. Some states do not allow the exclusion or limitation of incidental or consequential damages, so the above limitation or exclusion may not apply to you. This Warranty gives you specific legal rights, and you may also have other rights which vary from state to state.

