

EB and EBF Plug-in Detector Bases For Use With ED-Series Detectors

3825 Ohio Avenue, St. Charles, Illinois 60174
1-800-SENSOR2, FAX: 630-377-6495
www.systemsensor.com

Specifications

Diameter:	6.1 inches (155 mm); EBF 4.0 inches (102 mm); EB
Wire Gauge:	12 to 18 AWG (0.9 to 3.25 mm ²)

BEFORE INSTALLING

Please thoroughly read the system wiring and installation manuals and the System Smoke Detector Application Guide, which provides detailed information on detector spacing, placement, zoning, and special applications.

NOTICE: This manual should be left with the owner/user of this equipment. For use with models ED-P, ED-PT, ED-T, 63-1052, 63-1053, and 60-1039 detector heads.

MOUNTING

Detector base, Model EBF (Figure 1A), mounts directly to 3¹/₂ inch and 4 inch octagon boxes, 4 inch square boxes (with or without plaster rings) and single gang boxes. To mount, remove the decorative ring by turning it in either direction to unhook the snaps, then separate the ring from the base. Install the base on the box using the screws supplied with the junction box and the appropriate mounting slots in the base. Place the decorative ring on the base and rotate it in either direction until it snaps into place.

Detector base, Model EB (Figure 1B), mounts to 3¹/₂ inch octagon boxes, 4 inch square boxes with plaster rings, and European boxes with 50, 60, and 70 mm screw spacing. Install the base on the box using the screws supplied with the junction box and the appropriate mounting slots in the base.

Figure 1A: EBF 6 inch mounting base

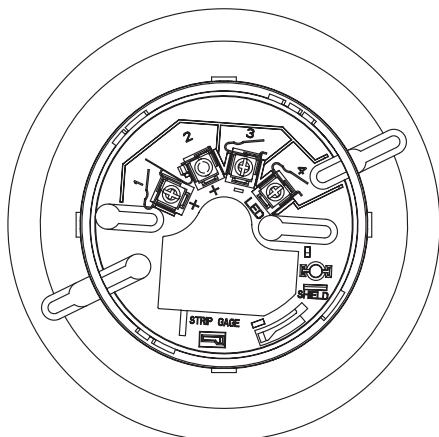

C0111-00

WIRING

All wiring must be installed in compliance with all applicable local codes and any special requirements of the authority having jurisdiction, using the proper wire size.

Figure 1B: EB 4 inch mounting base

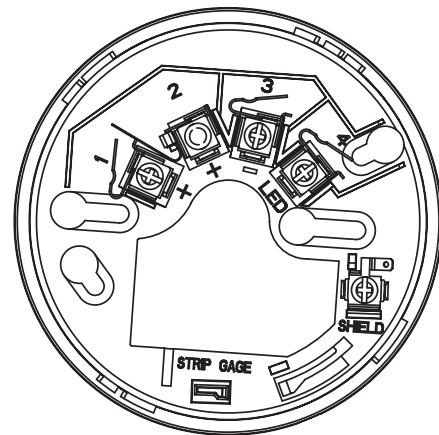

C0112-00

The conductors used to connect smoke detectors to control panels and accessory devices should be color-coded to reduce the likelihood of wiring errors. Improper connections can prevent a system from responding properly in the event of a fire. For signal wiring (the wiring between interconnected detectors), it is recommended that the wire be no smaller than AWG 18. However, the screws and clamping plate in the base can accommodate wire sizes up to AWG 12. If shielded cable is used, the shield connection to and from the detector must be continuous by using wire nuts, crimping, or soldering, as appropriate, for a reliable connection. Model EB has an additional terminal connection for use with shielded cable.

See Figure 2 for proper base wiring. Make electrical connections by stripping about 3/8" (10 mm) of insulation from the end of the wire (use strip gauge molded in base), sliding the bare end of the wire under the clamping plate, and tightening the clamping plate screw. Do not loop the wire under the clamping plate. The wiring of the detector base should be checked before the detector heads are installed in them. The wiring should be checked for continuity and polarity in the base, and dielectric tests should be performed. The base includes a space for recording the zone, address, and type of detector being installed. This information is important to set the address of the detector head that will later be plugged into the base and to verify the type required for that location.

Figure 2: Wiring the bases

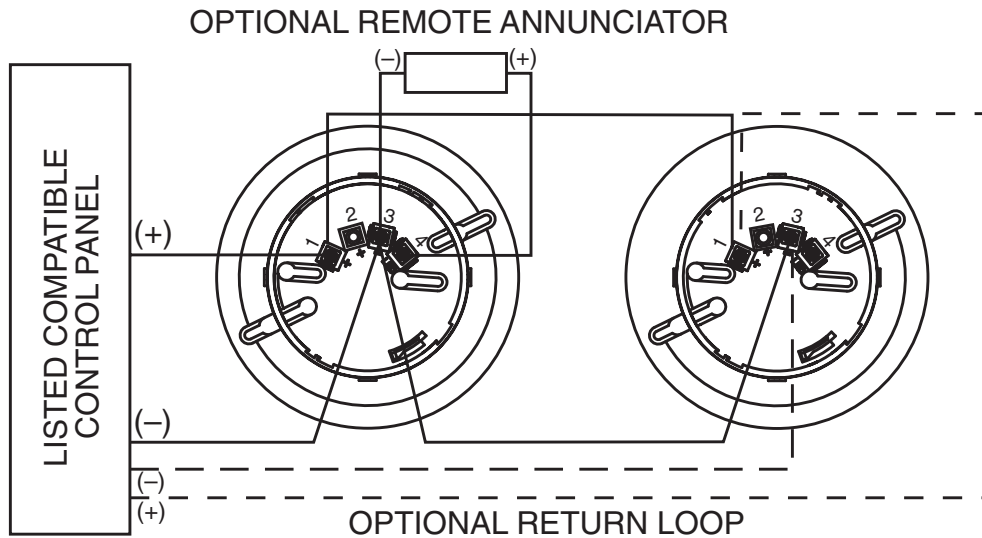

C0113-00

TERMINAL DEFINITIONS

T1	(+) SLC in/out	T3	(-) SLC in/out
T4	LED		

Figure 3A:

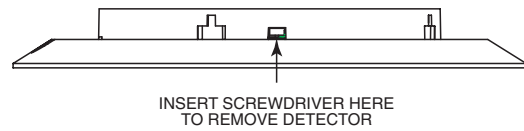

C0114-00

TAMPERPROOF FEATURE

This detector base also includes an optional tamperproof feature that, when activated, prevents removal of the detector without the use of a tool. To activate this feature, simply break off the tab on the lever on the detector base shown in Figure 3A, and install the detector. To remove the detector from the base once the tamperproof feature has been activated, place a small-bladed screwdriver into the small hole on the side of the base and push the plastic lever (see Figure 3B). This will allow the detector to be rotated counterclockwise for removal. The tamperproof feature may be defeated by breaking and removing the plastic lever from the base; however, this prevents the feature from being used again.

Figure 3B:

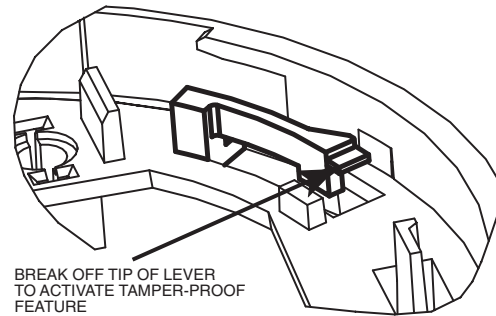

C0115-00

REMOTE ANNUNCIATOR (RA400Z)

The remote annunciator is connected between terminals 1 and 4 using the spade lug terminal packed with the remote annunciator. The spade lug terminal is connected to the base terminal as shown in Figure 4. It is not acceptable to have three stripped wires under the same wiring terminal unless they are separated by a washer or equivalent means. The spade lug supplied with the model RA400Z is considered acceptable. See Figure 2 for proper installation.

Figure 4:

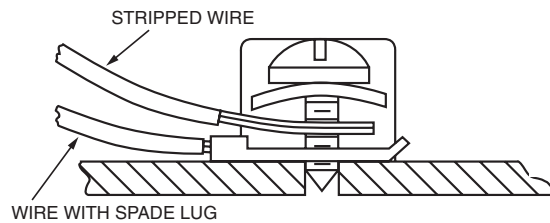

C0116-00

Please refer to insert for the Limitations of Fire Alarm Systems

Three-Year Limited Warranty

System Sensor warrants its enclosed smoke detector base to be free from defects in materials and workmanship under normal use and service for a period of three years from date of manufacture. System Sensor makes no other express warranty for this smoke detector base. No agent, representative, dealer, or employee of the Company has the authority to increase or alter the obligations or limitations of this Warranty. The Company's obligation of this Warranty shall be limited to the repair or replacement of any part of the smoke detector base which is found to be defective in materials or workmanship under normal use and service during the three year period commencing with the date of manufacture. After phoning System Sensor's toll free number 800-SENSOR2 (736-7672) for a Return Authorization number, send defective units postage prepaid to: System

Sensor, Returns Department, RA # _____, 3825 Ohio Avenue, St. Charles, IL 60174. Please include a note describing the malfunction and suspected cause of failure. The Company shall not be obligated to repair or replace units which are found to be defective because of damage, unreasonable use, modifications, or alterations occurring after the date of manufacture. In no case shall the Company be liable for any consequential or incidental damages for breach of this or any other Warranty, expressed or implied whatsoever, even if the loss or damage is caused by the Company's negligence or fault. Some states do not allow the exclusion or limitation of incidental or consequential damages, so the above limitation or exclusion may not apply to you. This Warranty gives you specific legal rights, and you may also have other rights which vary from state to state.