

EM-1M Monitor Module

SPECIFICATIONS

Normal Operating Voltage:	15 to 30 VDC
Standby Current:	485µA max. (continuous broadcasts); 745µA max. avg. (continuous broadcasts, IDC Shorted)
IDC Voltage:	5.4 VDC max.
Alarm Current:	2.0 mA (red LED on)
Maximum IDC Wiring Resistance:	100 Ω
Temperature Range:	32°F to 120°F (0°C to 49°C)
Humidity:	10 to 93% RH Non-condensing
Dimensions:	4.17" H x 4.26" W x 1.22" D; (106 mm H x 108 mm W x 31 mm D)
Accessories:	39 kΩ End of Line Resistor, part #A2263-00 (included) 14 kΩ Alarm Resistor, part #A3026-000 (not included) Wall cover plate (included) SMB500 Surface Mount Electrical Box

BEFORE INSTALLING

This information is included as a quick reference installation guide. Refer to the appropriate control panel installation manual for detailed system information. If the modules will be installed in an existing operational system, inform the operator and local authority that the system will be temporarily out of service.

NOTICE: This manual should be left with the owner/user of this equipment.

GENERAL DESCRIPTION

Monitor Module, Model EM-1M is used to monitor the normally open contacts of an auxiliary device. In addition to monitoring the contact, the device will monitor the wiring to the device for open circuits via an end of line resistor. This device is capable of Class A or Class B operation.

COMPATIBILITY REQUIREMENTS

To ensure proper operation, this module shall be connected to a listed compatible control panel.

MOUNTING

The module mounts directly to 4" square electrical boxes. The box must have a minimum depth of 2 1/8". Modules must be mounted with the arrow facing upward for proper operation of the IR programming tool. Surface mounted electrical boxes (SMB500) are available from System Sensor. (SMB500) are available from System Sensor.

WIRING

NOTE: All wiring must conform to applicable local codes, ordinances, and regulations.

1. Install module wiring in accordance with the job drawings and appropriate wiring diagrams.
2. For new installations use the enclosed 39 IQ EOL resistor. For retrofit applications where the existing 47 kΩ cannot be easily replaced, it may be left in place without loss of performance.

3. Set the address on the module per job drawings using the IR configuration tool (model no. EA-CT).
4. Secure module to electrical box (supplied by installer).

TERMINAL DEFINITIONS

T1	(+) SLC in/out	T7	(-) IDC Class A/B
T2	(-) SLC in/out	T8	(+) IDC Class A/B
T3	(+) SLC in/out	T9	(+) IDC Class A
T4	(-) SLC in/out	T10	(-) IDC Class A

FIGURE 1. MONITOR MODULE:

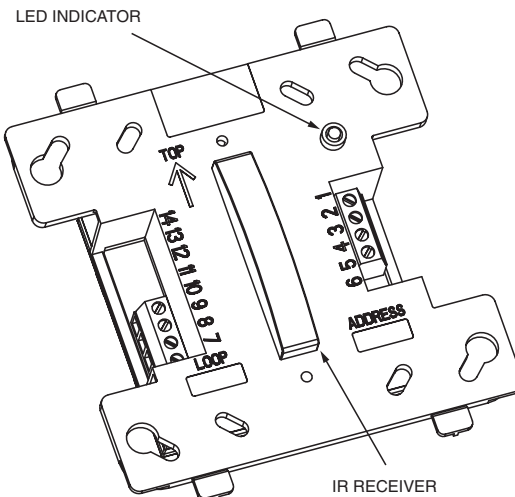

C0102-00

FIGURE 2. TYPICAL 2-WIRE IDC CONFIGURATION, NFPA CLASS B/STYLE B:

ALL WIRING SHOWN IS SUPERVISED AND POWER LIMITED

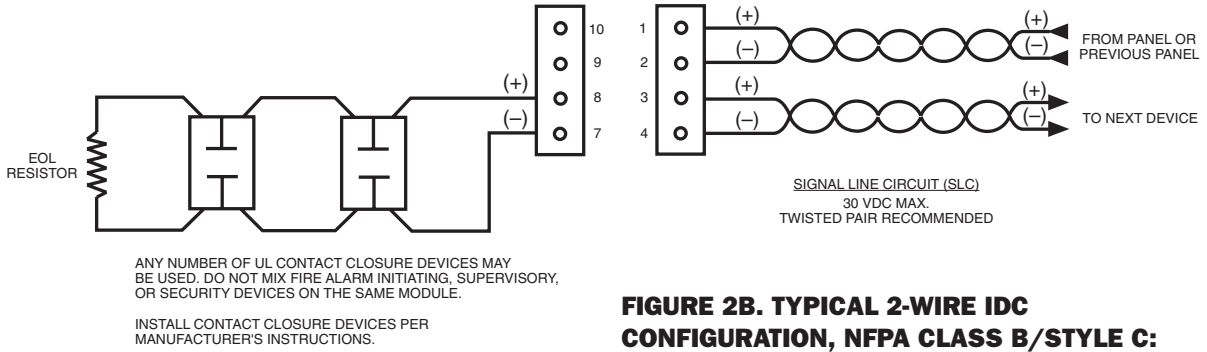

C1013-01

FIGURE 2B. TYPICAL 2-WIRE IDC CONFIGURATION, NFPA CLASS B/STYLE C:

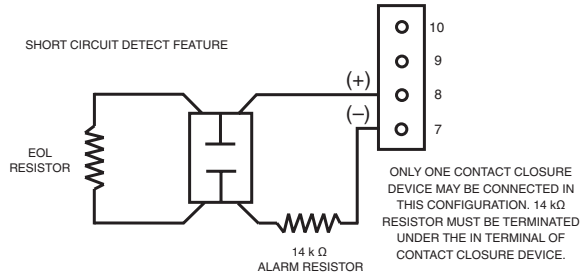

C1019-00

FIGURE 3. TYPICAL 4-WIRE FAULT TOLERANT IDC CONFIGURATION, NFPA CLASS A/STYLE D:

ALL WIRING SHOWN IS SUPERVISED AND POWER LIMITED

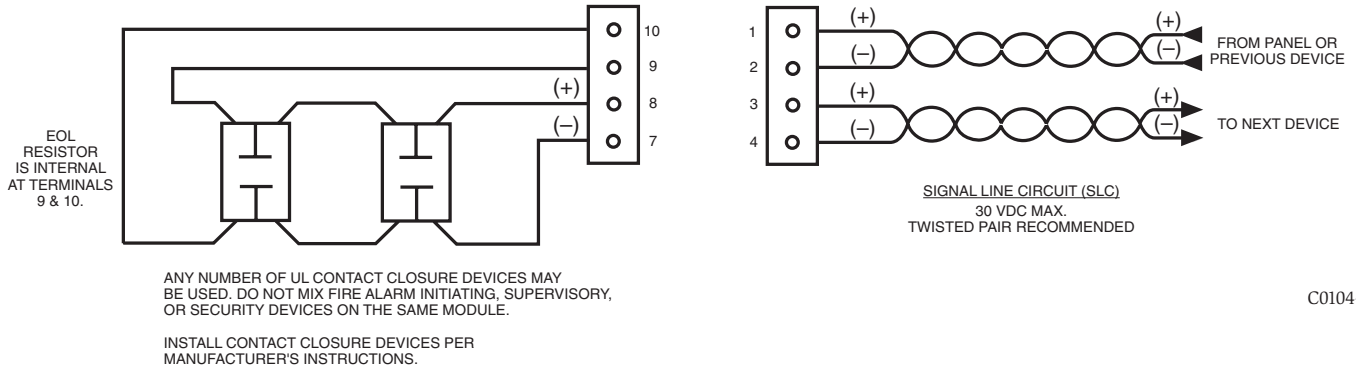

C1014-01

THREE-YEAR LIMITED WARRANTY

System Sensor warrants its enclosed product to be free from defects in materials and workmanship under normal use and service for a period of three years from date of manufacture. System Sensor makes no other express warranty for this air duct smoke detector. No agent, representative, dealer, or employee of the Company has the authority to increase or alter the obligations or limitations of this Warranty. The Company's obligation of this Warranty shall be limited to the replacement of any part of the product which is found to be defective in materials or workmanship under normal use and service during the three year period commencing with the date of manufacture. After phoning System Sensor's toll free number 800-SENSOR2 (736-7672) for a Return Authorization number, send defective units postage prepaid to: System Sensor, Returns Department, RA

_____, 3825 Ohio Avenue, St. Charles, IL 60174. Please include a note describing the malfunction and suspected cause of failure. The Company shall not be obligated to replace units which are found to be defective because of damage, unreasonable use, modifications, or alterations occurring after the date of manufacture. In no case shall the Company be liable for any consequential or incidental damages for breach of this or any other Warranty, expressed or implied whatsoever, even if the loss or damage is caused by the Company's negligence or fault. Some states do not allow the exclusion or limitation of incidental or consequential damages, so the above limitation or exclusion may not apply to you. This Warranty gives you specific legal rights, and you may also have other rights which vary from state to state.

FCC STATEMENT

This device complies with part 15 of the FCC Rules. Operation is subject to the following two conditions: (1) This device may not cause harmful interference, and (2) this device must accept any interference received, including interference that may cause undesired operation.

NOTE: This equipment has been tested and found to comply with the limits for a Class B digital device, pursuant to Part 15 of the FCC Rules. These limits are designed to provide reasonable protection against harmful interference in a residential installation. This equipment generates, uses and can radiate radio frequency energy and, if not installed and used in accordance with the instructions, may cause harmful interference to radio communications. However, there is no guarantee that interference will not occur in a particular installation. If this equipment does cause harmful interference to radio or television reception, which can be determined by turning the equipment off and on, the user is encouraged to try to correct the interference by one or more of the following measures:

- Reorient or relocate the receiving antenna.
- Increase the separation between the equipment and receiver.
- Connect the equipment into an outlet on a circuit different from that to which the receiver is connected.
- Consult the dealer or an experienced radio/TV technician for help.