



3825 Ohio Avenue, St. Charles, Illinois 60174
 1-800-SENSOR2, FAX: 630-377-6495
 www.systemsensor.com

EM-1SR Supervised Control Module

SPECIFICATIONS

Normal Operating Voltage:	15 to 30 VDC
Standby Current:	630 μ A max. average (continuous broadcasts)
Alarm Current:	2 mA (red LED on)
Maximum NAC Circuit Line Loss:	4 VDC
Power Supply Monitor	
Maximum (Speakers):	70.7 V RMS, 50 W
Maximum (NAC):	Regulated 24VDC
Trouble Range:	0 to 2 VDC
Max. NAC Current Ratings:	For Class B wiring system, 3A For Class A wiring system, 2A
Temperature Range:	32°F to 120°F (0°C to 49°C)
Humidity:	10 to 93% RH Non-condensing
Dimensions:	4.17" H x 4.26" W x 1.22" D (106 mm H x 108 mm W x 31 mm D)
Accessories:	39 k Ω End of Line Resistor Part # A2263-00 (included) Wall cover plate (included) SMB500 Surface Mount Electrical Box A2143-60 Bypass capacitor EA-CB Control Module Barrier

BEFORE INSTALLING

This information is included as a quick reference installation guide. Refer to the appropriate control panel installation manual for detailed system information. If the modules will be installed in an existing operational system, inform the operator and local authority that the system will be temporarily out of service.

NOTICE: This manual should be left with the owner/user of this equipment.

GENERAL DESCRIPTION

Control Module, Model EM-1SR, is used to switch an external power supply or audio amplifier to notification appliances. In addition to switching the external power, the device will monitor the wiring (while external power is not switched to the auxiliary devices) to the auxiliary device for open and short circuits via an end of line resistor. This module is capable of Class A or Class B operation.

The control module will also have the capability to monitor the external power input for loss of power (DC voltage supplies only). This feature can be disabled through device configuration programming. If the external power is switched to the auxiliary devices and there is a loss of the DC supply, the control module has the capability of running an algorithm in which the device will switch back to monitor mode and check the line for short circuits. If no short exists, the device will reapply the external power. This algorithm can be enabled when using a DC external supply that is guaranteed to be above 9 volts.

COMPATIBILITY REQUIREMENTS

To ensure proper operation, this module shall be connected to a listed compatible control panel.

MOUNTING

The module mounts directly to 4" square electrical boxes. The box must have a minimum depth of 2¹/₈". Modules must be mounted with the arrow facing upward for proper operation of the IR programming tool. Surface mounted electrical boxes (SMB500) are available from System Sensor.

WIRING

NOTE: All wiring must conform to applicable local codes, ordinances, and regulations.

1. Install module wiring in accordance with the job drawings and appropriate wiring diagrams. Optional EA-CB may be required to separate power limited and non power limited wiring in the electrical box.
2. For new installations use the enclosed 39 k Ω EOL resistor. For retrofit applications where the existing 47 k Ω cannot be easily replaced, it may be left in place without loss of performance.
3. Set the address on the module per job drawings using the handheld IR programmer.
4. Secure module to electrical box (supplied by installer).

TESTING

The following resistance values can be used to test the module after installation:

- Short Circuit: < 50Ω
- Open Circuit: > 1MΩ
- Ground Fault: < 50Ω



All relay switch contacts are shipped in the standby state (open) state, but may have transferred to the activated (closed) state during shipping. To ensure that the switch contacts are in their correct state, modules must be made to communicate with the panel before connecting circuits controlled by the module.

TERMINAL DEFINITIONS

T1 (+) SLC in/out	T9 (-) external power line in/out
T2 (-) SLC in/out	T10 (+) external power line in/out
T3 (+) SLC in/out	T11 NAC (+) A/B
T4 (-) SLC in/out	T12 NAC (-) A/B
T7 (-) external power line in/out	T13 NAC (-) Class A
T8 (+) external power line in/out	T14 NAC (+) Class A

Figure 1: Supervised Control Module

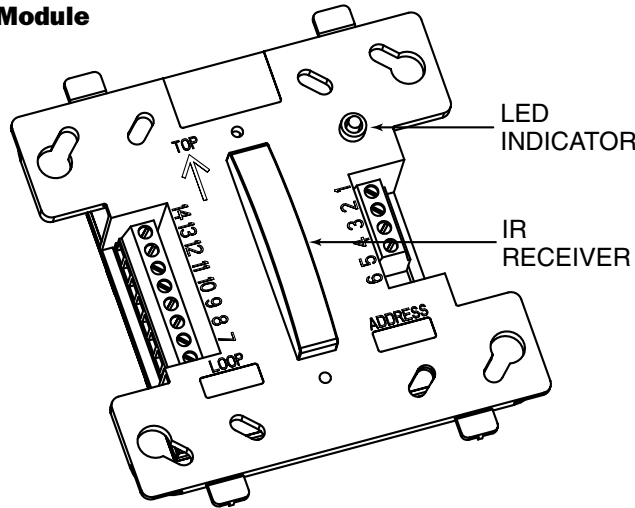

C0164-00

Figure 2: Typical Class B, Style Y NAC configuration.

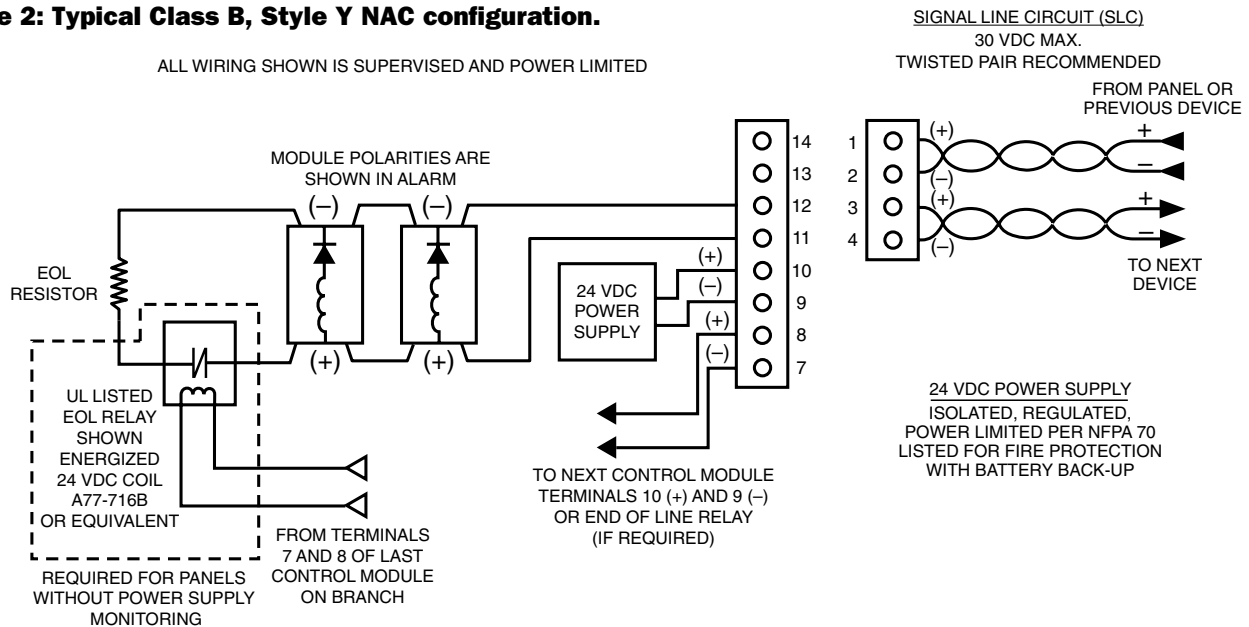

C0106-04

Figure 3: Typical Class A, Style Z NAC configuration.

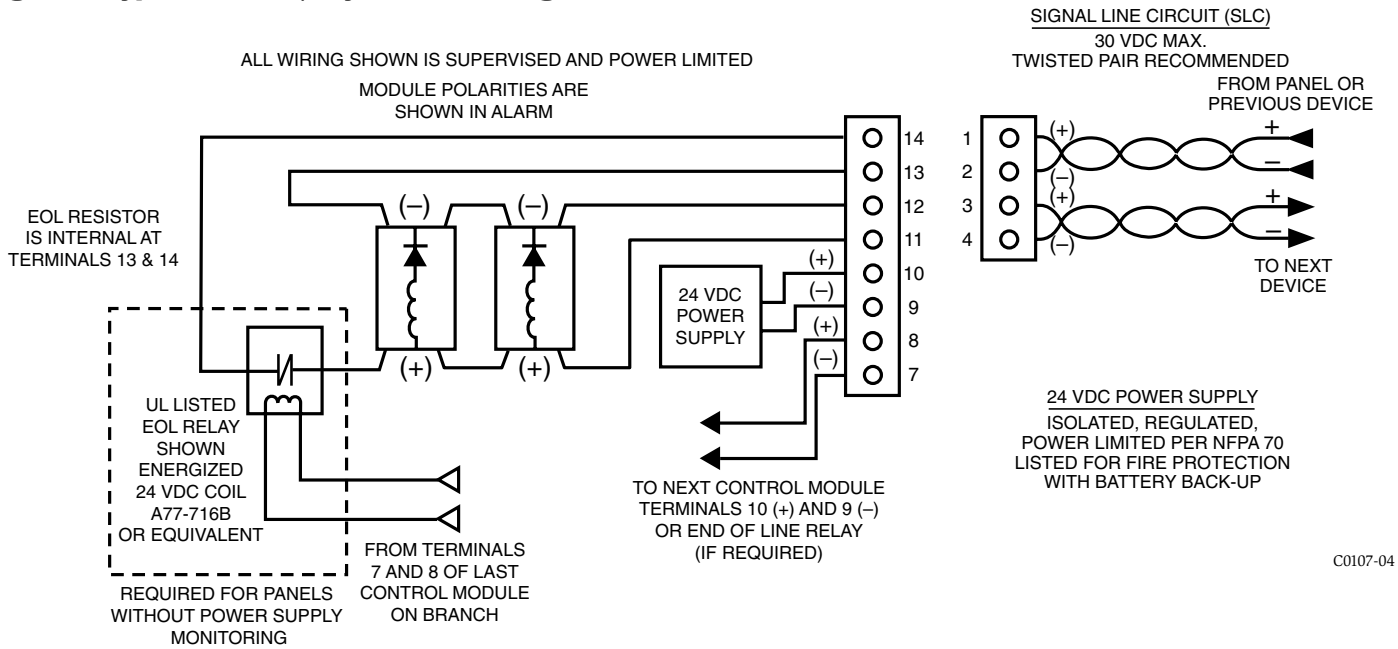

Figure 4: Typical Class B, Style Y Audio NAC configuration.

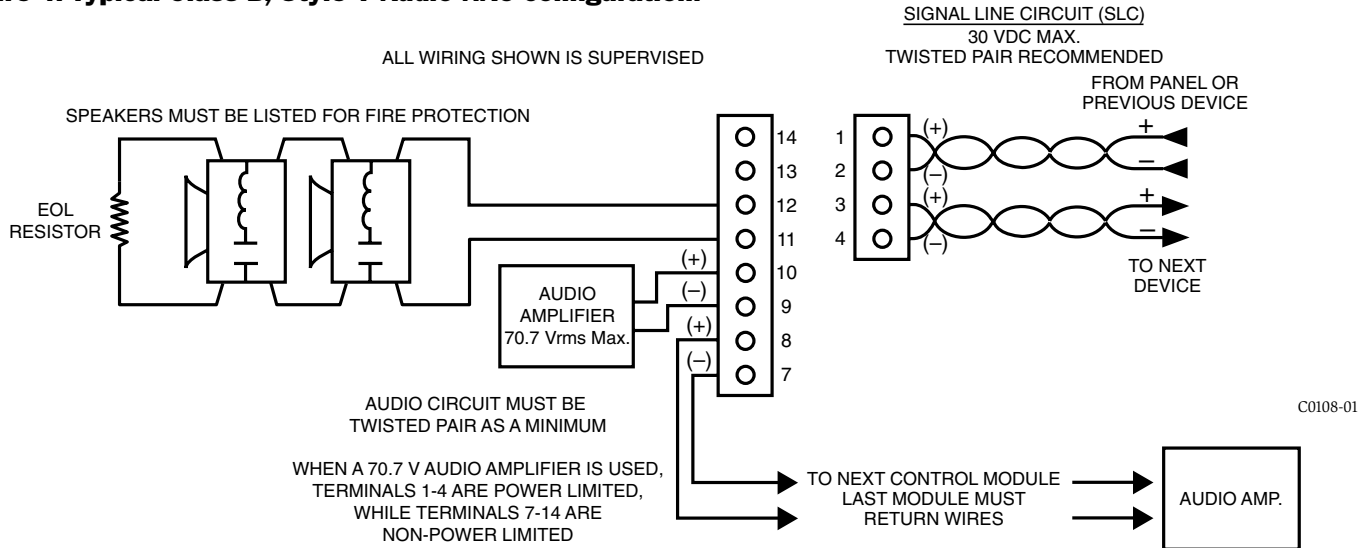
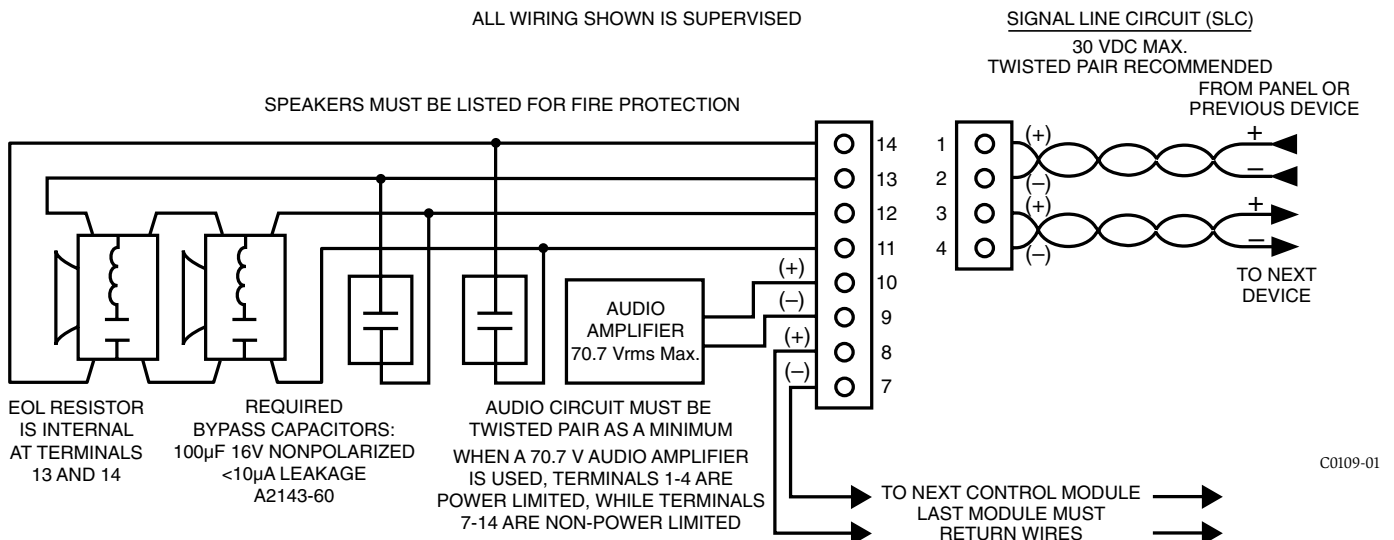

Figure 5: Typical Class A, Style Z Audio NAC configuration.



Three-Year Limited Warranty

System Sensor warrants its enclosed product to be free from defects in materials and workmanship under normal use and service for a period of three years from date of manufacture. System Sensor makes no other express warranty for this air duct smoke detector. No agent, representative, dealer, or employee of the Company has the authority to increase or alter the obligations or limitations of this Warranty. The Company's obligation of this Warranty shall be limited to the replacement of any part of the product which is found to be defective in materials or workmanship under normal use and service during the three year period commencing with the date of manufacture. After phoning System Sensor's toll free number 800-SENSOR2 (736-7672) for a Return Authorization number, send defective units postage prepaid to: System Sensor, Returns

Department, RA #_____, 3825 Ohio Avenue, St. Charles, IL 60174. Please include a note describing the malfunction and suspected cause of failure. The Company shall not be obligated to replace units which are found to be defective because of damage, unreasonable use, modifications, or alterations occurring after the date of manufacture. In no case shall the Company be liable for any consequential or incidental damages for breach of this or any other Warranty, expressed or implied whatsoever, even if the loss or damage is caused by the Company's negligence or fault. Some states do not allow the exclusion or limitation of incidental or consequential damages, so the above limitation or exclusion may not apply to you. This Warranty gives you specific legal rights, and you may also have other rights which vary from state to state.

FCC Statement

This device complies with part 15 of the FCC Rules. Operation is subject to the following two conditions: (1) This device may not cause harmful interference, and (2) this device must accept any interference received, including interference that may cause undesired operation.

NOTE: This equipment has been tested and found to comply with the limits for a Class B digital device, pursuant to Part 15 of the FCC Rules. These limits are designed to provide reasonable protection against harmful interference in a residential installation. This equipment generates, uses and can radiate radio frequency energy and, if not installed and used in accordance with the instructions, may cause harmful interference to radio communications. However, there is no guarantee that interference will not occur in a particular installation. If this equipment does cause harmful interference to radio or television reception, which can be determined by turning the equipment off and on, the user is encouraged to try to correct the interference by one or more of the following measures:

- Reorient or relocate the receiving antenna.
- Increase the separation between the equipment and receiver.
- Connect the equipment into an outlet on a circuit different from that to which the receiver is connected.
- Consult the dealer or an experienced radio/TV technician for help.