

M500DM Dual Monitor Module

SPECIFICATIONS

Normal Operating Voltage:	15 to 32 VDC
Maximum Current Draw:	6.4 mA (LED on)
Average Operating Current:	750 μ A (LED flashing)
EOL Resistance:	47K Ohms
Maximum SLC wiring resistance:	40 Ohms
Maximum IDC wiring resistance:	1,500 Ohms
Maximum IDC Voltage:	11 Volts
Maximum IDC Current:	240 μ A
Temperature Range:	32°F to 120°F (0°C to 49°C)
Humidity:	10% to 93% Non-condensing
Dimensions:	4 $\frac{1}{2}$ in H x 4.275 in W x 1.4 in D (Mounts to a 4-inch square by 2 $\frac{1}{8}$ -inch deep box.)
Accessories:	SMB500 Electrical Box

BEFORE INSTALLING

This information is included as a quick reference installation guide. Refer to the control panel installation manual for detailed system information. If the modules will be installed in an existing operational system, inform the operator and local authority that the system will be temporarily out of service. Disconnect power to the control panel before installing the modules.

NOTICE: This manual should be left with the owner/user of this equipment.

GENERAL DESCRIPTION

The Dual Monitor Module is intended for use in intelligent, two wire systems. It provides two independent 2-wire initiating device circuits (IDC), at two separate, consecutive addresses. It is capable of monitoring normally open contact fire alarm and supervisory devices, or either normally open or normally closed security devices.

COMPATIBILITY REQUIREMENTS

To ensure proper operation, these modules shall be connected to listed compatible system control panels only.

FIGURE 1. CONTROLS AND INDICATORS:

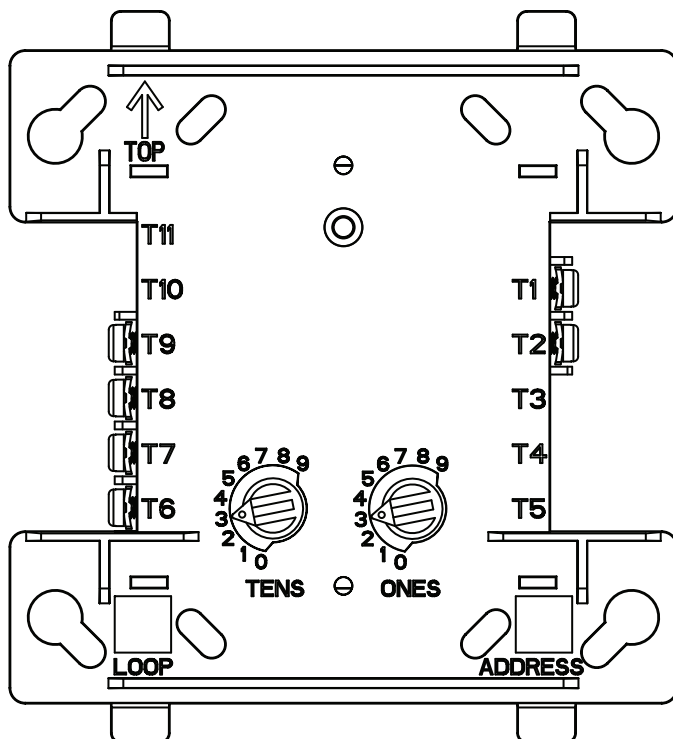

MOUNTING

Mounts directly to 4-inch square electrical boxes (see Figure 2A). The box must have a minimum depth of 2 $\frac{1}{8}$ inches. Surface mounted electrical boxes (SMB500) are available from System Sensor.

FIGURE 2. MODULE MOUNTING: FIGURE 2B:

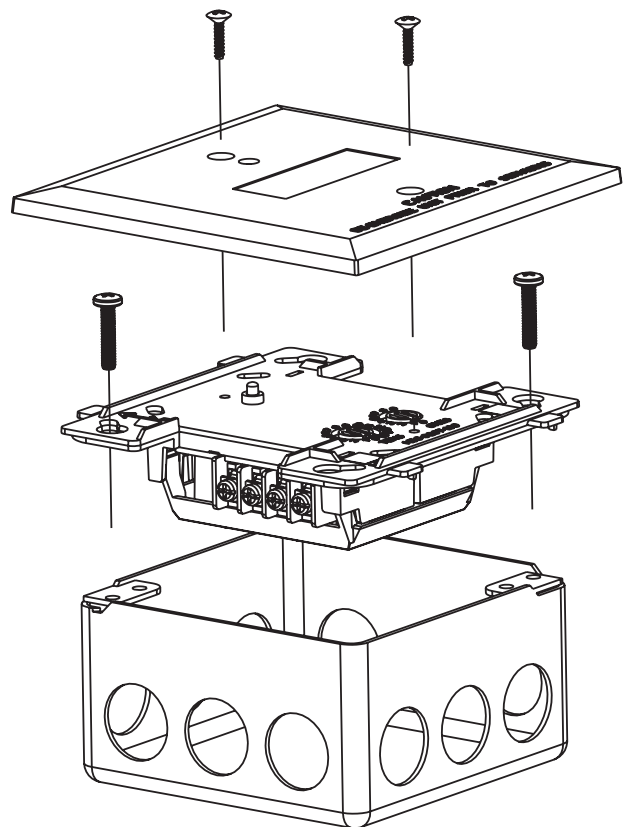

C1075-00

WIRING

NOTE: All wiring must conform to applicable local codes, ordinances, and regulations. This module is intended for power limited wiring only.

1. Install module wiring in accordance with the job drawings and appropriate wiring diagrams.
2. Set the address on the module per job drawings.

NOTE: Monitor module L (using terminals 6 and 7) responds at the address set on the code switches. Monitor module H (using terminals 8 and 9) will automatically respond at the next higher address. For example, if the code switches are set to 76, module L will respond at address 76 and module H will respond at address 77. Use caution to avoid duplicate addressing of modules on the system.

3. Secure module to electrical box (supplied by installer), as shown in Figure 2.

FIGURE 3. TYPICAL 2-WIRE INITIATING CIRCUIT CONFIGURATION, NFPA STYLE B:

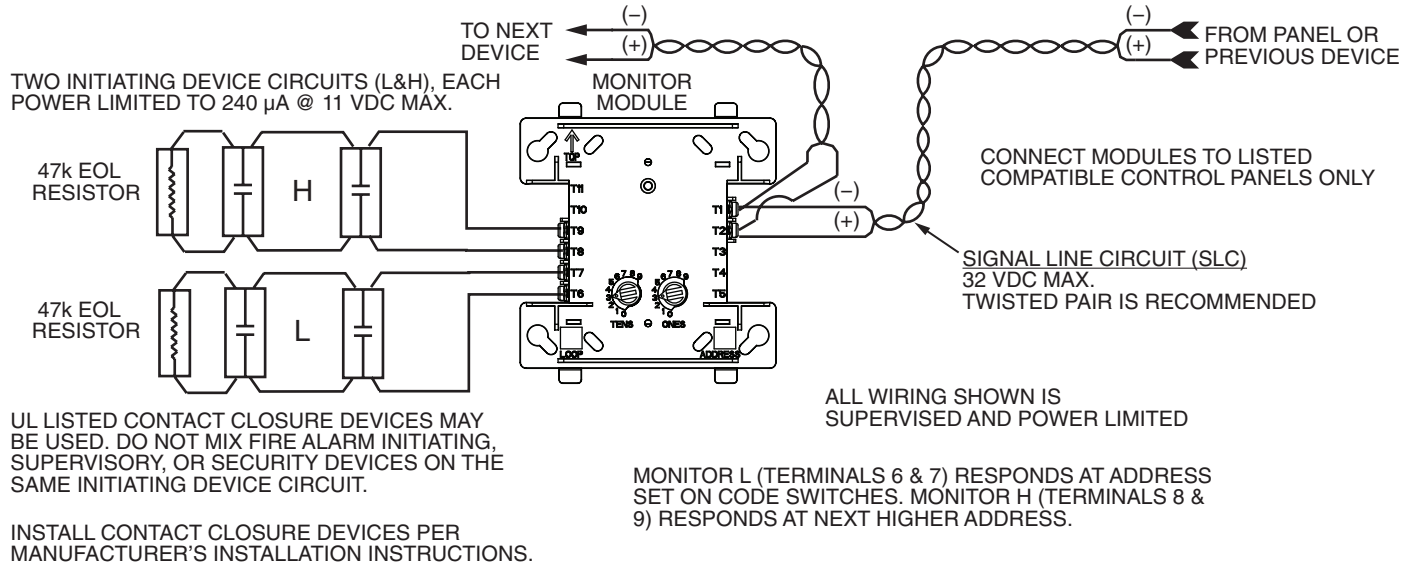

C1074-07

THREE-YEAR LIMITED WARRANTY

System Sensor warrants its enclosed product to be free from defects in materials and workmanship under normal use and service for a period of three years from date of manufacture. System Sensor makes no other express warranty for the enclosed product. No agent, representative, dealer, or employee of the Company has the authority to increase or alter the obligations or limitations of this Warranty. The Company's obligation of this Warranty shall be limited to the replacement of any part of the product which is found to be defective in materials or workmanship under normal use and service during the three year period commencing with the date of manufacture. After phoning System Sensor's toll free number 800-SENSOR2 (736-7672) for a Return Authorization number, send defective units postage prepaid to: System Sensor, Returns Department, RA

_____, 3825 Ohio Avenue, St. Charles, IL 60174. Please include a note describing the malfunction and suspected cause of failure. The Company shall not be obligated to replace units which are found to be defective because of damage, unreasonable use, modifications, or alterations occurring after the date of manufacture. In no case shall the Company be liable for any consequential or incidental damages for breach of this or any other Warranty, expressed or implied whatsoever, even if the loss or damage is caused by the Company's negligence or fault. Some states do not allow the exclusion or limitation of incidental or consequential damages, so the above limitation or exclusion may not apply to you. This Warranty gives you specific legal rights, and you may also have other rights which vary from state to state.

FCC STATEMENT

This equipment has been tested and found to comply with the limits for a Class B digital device, pursuant to Part 15 of the FCC rules. These limits are designed to provide reasonable protection against harmful interference. This equipment generates, uses, and can radiate radio frequency energy and, if not installed and used in accordance with the instruction manual, may cause harmful interference to radio communications. Operation is subject to the following two conditions: (1) This device may not cause harmful radiation, and (2) this device must accept any interference received, including interference that may cause undesired operation.